

REV	RELEASE	DESCRIPTION	APPR	DATE
A	NEW	INITIAL RELEASE	PD	9/25/19
A	UPDATE	UPDATED SPEC.	PD	9/13/20

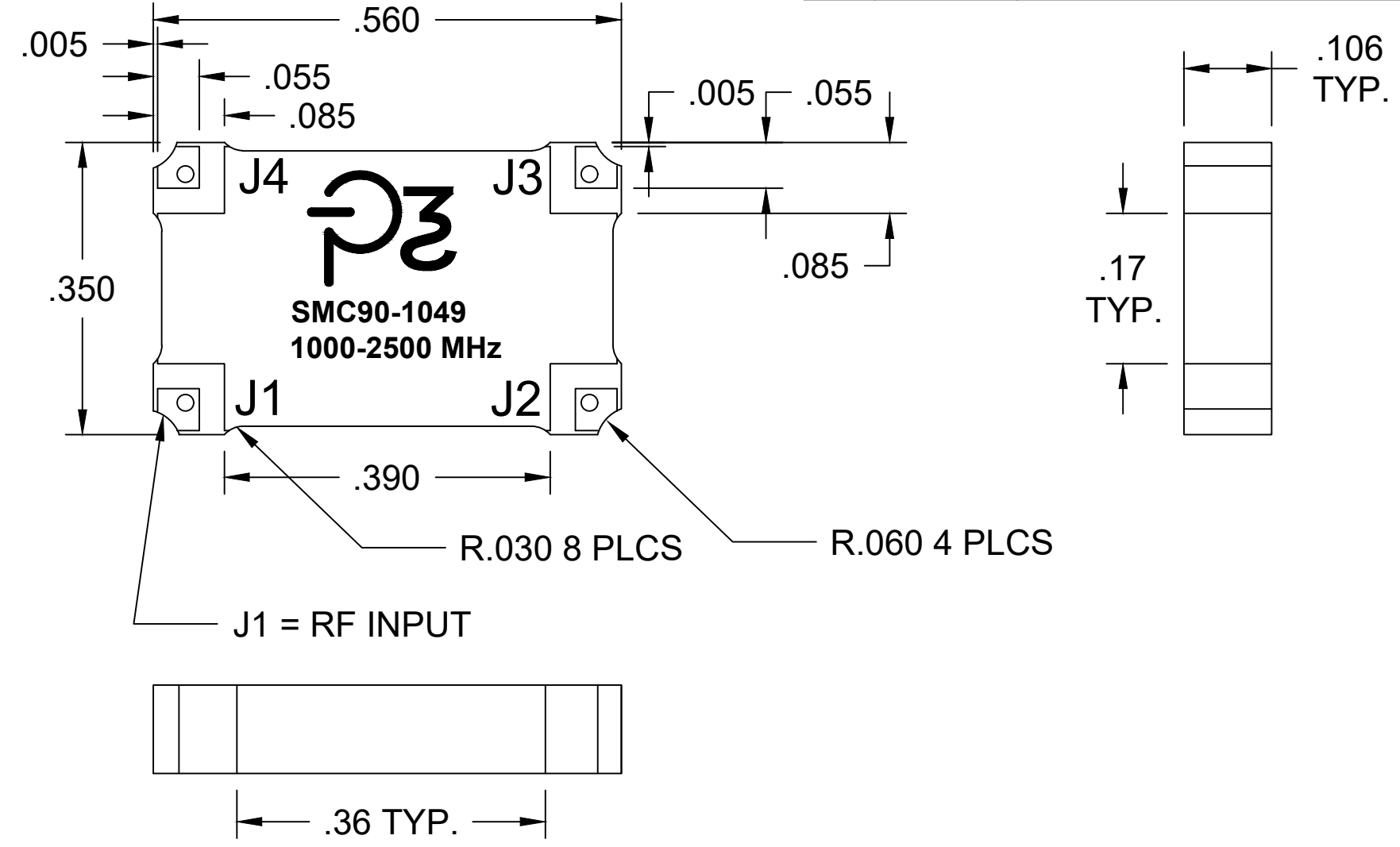

PORT CONFIGURATION

PORTS	J1	J2	J3	J4
J1	--	ISO	-3dB 0°	-3dB -90°
J2	ISO	--	-3dB -90°	-3dB 0°
J3	-3dB 0°	-3dB -90°	--	ISO
J4	-3dB -90°	-3dB 0°	ISO	--

SPECIFICATIONS:

Frequency: 1000-2500 MHz.
 Power: 150 Watts CW
 Insertion Loss: <0.25 dB MAX.
 Isolation: >19 dB MIN.
 Phase Bal.: ±5.0° MAX.
 VSWR: <1.25:1 MAX.
 Amplitude Bal.: ±0.70 dB MAX.
 Oper. Temp.: -55° to +85°C

MECHANICAL:

Board Material: PTFE
 Finish: Immersion Tin Plate
 NOTE:
 RELPACES IPP-7055
 WERLATONE QH9139



 PREFERRED POWER PRODUCTS STUART, FLORIDA 34997	UNLESS OTHERWISE SPECIFIED ALL DIMENSIONS ARE IN INCHES TOLERANCES: <table border="0"> <tr> <td>DECIMALS</td> <td>ANGULAR</td> </tr> <tr> <td>.X ± .1</td> <td>± .5°</td> </tr> <tr> <td>.XX ± .01</td> <td></td> </tr> <tr> <td>.XXX ± .005</td> <td></td> </tr> </table>	DECIMALS	ANGULAR	.X ± .1	± .5°	.XX ± .01		.XXX ± .005		PART NO. SMC90-1049 HYBRID COUPLER, SMC 90 DEG. 1000-2500 MHz. 150 WATT	
	DECIMALS	ANGULAR									
.X ± .1	± .5°										
.XX ± .01											
.XXX ± .005											
THIS DRAWING AND ALL CONTENTS HEREIN, ARE THE SOLE, PROPRIETARY PROPERTY OF PREFERRED POWER PRODUCTS, LLC AND MAY NOT BE USED, REPRODUCED OR DISCLOSED WITHOUT EXPRESSED WRITTEN CONSENT.	CHECKED PD 9/25/19 DRAWN PD 9/25/19 CAGE CODE 7W5T7	APPROVED PD 9/25/19 ENGINEER PD 9/25/19 SCALE 1:1	SHEET 1 OF 1								